

MACHINES & TOOLS FOR PROFESSIONALS

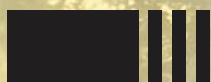

Gewindeschneiden
Threading

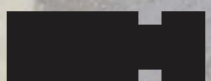

Rollnuten
Grooving



Biegen
Bending



Bördeln
Flaring / Flanging



Schneiden
Cutting

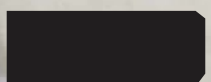

Entgraten
Reaming



Bohren / Stanzen
Drilling / Punching

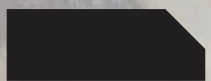

Anfasen
Beveling



Schleifen
Grinding

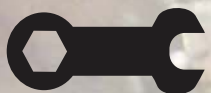

Installationswerkzeuge
Installation tools

Image	Series	O.D.	MOTOR	kg	r.p.m.	Make
	Pg. 4 NP50AV	1/4 - 2"	230V 700W Series motor	46kg	39 rpm	
	Pg. 6 NR50AV	1/4 - 2"	230V 700W Series motor	46kg	39 rpm	
	Pg. 8 NP80AV	1/4 - 3"	230V 700W Series motor	67kg	33 rpm	
	Pg. 10 N100A	1/4 - 4"	230V 750W Condenser motor	123kg	13/24/43rpm	
	Pg. 12 Gewindeschneidköpfe Diehead					
	Pg. 13 Schneidbacken Dies					
	Pg. 15 Roll-köpfe Roll head					
	Pg. 16 Rollnutgerät Groover					
	Pg. 18 Nuten-Anfassschneidkopt Cut groove / Bevel head					
	Pg. 18 Transportuntergestell Machine cart					
	Pg. 19 Rohrständer Pipe stand					
	Pg. 20 Nippelspannfutter / Gewindelehre / Gewindeschneidmittel Nipple attachment / Thread gauge / Oil					

Ⓚ Gewindeschneidköpfe Ⓚ Roll-köpfe Ⓚ Nuten-/Anfassschneidkopf Ⓚ Rollnutgerät
Ⓜ Diehead Ⓜ Roll diehead Ⓜ Cut grooving / Beveling diehead Ⓜ Rollgroove attachment

<p>Manual</p> <p>1/4-3/8, 1/2-2"</p>	<p>V-type</p> <p>1/2-2"</p>	<p>NV-type</p> <p>1/2-2"</p>	<p>Super auto</p> <p>1/2-3/4, 1-2"</p>	<p>Profiling</p> <p>3/8, 1/2, 3/4, 1"</p>	<p>Manual1-6", Hydraulic1-16"</p>
<p>1/2-2" 1/2-2"</p>					<p>Manual1-6", Hydraulic1-16"</p>
<p>1/4-3/8, 1/2-2, 2.1/2-3"</p>	<p>1/2-2" 1/2-2"</p>	<p>1/2-3/4, 1-2, 2.1/2-3"</p>	<p>3/8, 1/2, 3/4, 1, 1.1/4, 1.1/2, 2"</p>	<p>3/4-2, 2.1/2-3"</p>	<p>Manual1-6", Hydraulic1-16"</p>
<p>1/4-3/8, 1/2-2, 2.1/2-3"</p>	<p>1/2-2" 1/2-2"</p>	<p>1/2-3/4, 1-2, 2.1/2-3"</p>	<p>3/8, 1/2, 3/4, 1, 1.1/4, 1.1/2, 2"</p>	<p>3/4-2, 2.1/2-3, 2.1/2-4"</p>	<p>Manual1-6", Hydraulic1-16"</p>
<p>Tapered pipe</p> <p>Straight pipe</p> <p>Straight bolt</p>		<p>Roll thread</p> <p>eco</p> <p>Pg15</p>		<p>Cut grooving</p> <p>Bevelling</p> <p>Pg18</p>	
		<p>Roll grooving</p> <p>Pg16, 17</p>			

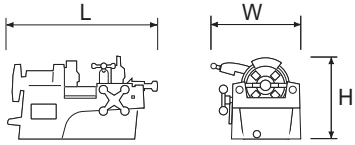

Dimension (mm)			
Model	L	W	H
NP50AV	700	440	408
NR50AV	700	440	408
NP80AV	760	500	465
N100A	873	635	558

Ø Inch	Ø mm.	wandstarke/Wall		Nominal mm.
		sched.10	sched.40	
3/4	26.7		2.9	20
1	33.4	2.8	3.4	25
1 1/4	42.2	2.8	3.6	32
1 1/2	48.3	2.8	3.7	40
2	60.3	2.8	3.9	50
2 1/2	73	3.0	5.2	65
3	88.9	3.0	5.5	80
3 1/2	101.6	3.0	5.7	95
4	114.3	3.4	6	100
5	141.3	3.4	6.6	125
6	168.3	3.4	7.1	150
8	219.1	3.8	8.2	200
10	273	4.2	9.3	250
12	323.9	4.6	10.3	300
14	355.6	6.4	11.1	350
16	406.4	6.4	12.7	400
18	457.2	6.4	14.3	450
20	508	6.4	15.1	500
22	558.8	6.4	15.1	550
24	609.6	6.4	17.4	600



CE230V
R/L

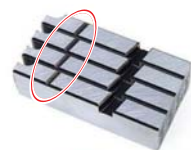

Ölpumpe



Sicherheit



NP50AV

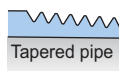

Tapered pipe

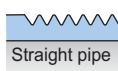

Straight pipe



Manual



NV auto



Super auto



27mm dies



38mm dies

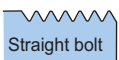

Straight bolt



Bolt diehead

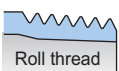

Roll thread



SRH20A

(D)

- Kompakt und leicht, 48kg
- Kraftvoll, hohe Produktivität
- Einfache Bedienung
- Einstellbare Gewindetiefe / Länge
- Auto. Stop Kohlebürste
- Recht / Links Drehung

(GB)

- Compact light weight 48kg
- Powerful, high productivity
- Portable user friendly
- Adjustable thread depth/length
- Auto. stop carbon brush-
- Right / Left rotation

(D) NP50AV Gewindeschneidmaschine						
(GB) NP50AV threading machine						
KW#	Type	Max. Cap. Ø				
230352	NP50AV	BSPT/NPT 2" MM52, WW1.1/4" UNC2"	700W 39rpm	48.0		

Dimension : 700(L) x 440(W) x 408 (H) mm

(D) Standard typ mit

(GB) Standard accessory:

- NVP-Auto diehead 1/2-2" (nr.293106),
- Alloy dies 1/2x3/4"BSPT (nr.291703),
- Alloy dies 1x2"BSPT (nr.291707),
- Reamer, cutter, foot switch, Legs.

(D) Gewindeschneidköpfe

(GB) Diehead for NP50AV

KW#	Type	Cap. Ø mm	
293106	NVP auto	1/2 - 2"	Pg12
----- other optional dieheads -----			
292901	Manual	1/4 - 3/8"	Pg12
293105	Manual	1/2 - 2"	
293105	VP auto	1/2 - 2"	
293301	Super auto	1/2 - 3/4"	
293303	Super auto	1 - 2"	

(D) Schneidbacken

(GB) Dies

KW#	Type	Cap. Ø	
291703	161907	27mm Alloy 1/2 - 3/4" BSPT	Pg13
291707	16K030	27mm Alloy 1 - 2" BSPT	
----- other optional dies -----			
2917**		Alloy 1/4 ~ 2" BSPT / NPT	Pg13
2917**		HSS 1/4 ~ 2" BSPT / NPT	Pg13
2918**		ARK 1/2 ~ 2" BSPT / NPT	Pg13
292***		BoltM8-M52, UNC5/16-2"	Pg14

(D) Bolzengewindeschneidköpfe

(GB) Bolt diehead for NP50AV

KW#	Cap. Ø mm	
2937**	MM, MF, BSW, UNC	Pg12

(D) Roll-köpfe

(GB) Roll diehead

KW#	Type	Cap. Ø	
29	SRH10A	3/8"	Pg15
293863	SRH15A	1/2"	
293865	SRH20A	3/4"	
293867	SRH25A	1"	

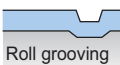
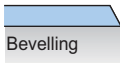
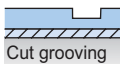

ⓓ Nuten-/Anfassschneidkopt				
Ⓞ Cut grooving / Bevelling diehead				
KW#	Type	Cap. Ø	Machine	
293750	GD2	3/4 - 2"	NP50A SNP80A N100A	Pg15
----- Schneidbacken -----				
		3/4 ~ 2"	Nutschneidbacken	Pg15
		3/4 ~ 2"	Anfassschneidbacken	

ⓓ Rollnutgerät				
Ⓞ Rollgroove attachment				
KW#	Type			
230913	RGRO	Portable Manual rollgroover 1-6"		Pg16,17
230931	RGRH	Portable Hydr. rollgroover 1-16"		

ⓓ Rohrschneidräder				
Ⓞ Machine cutter wheel				
KW#	Type			
295603	135076	Machine cutter wheel		Pg14
285605	135077	HSS machine cutter wheel		

ⓓ Transportuntergestell				
Ⓞ Machine cart				
KW#	Type			
296112	170245	Threader cart without adaptor		Pg18
276115	170266	Adaptor for NP50AV		



ⓓ Rohrständer						
Ⓞ Pipe support						
KW#	Type	Cap.	H.min	H.max		
296218	K100	Ø1-4"	850	1100	7.0	Pg19
296223	VS300/2S	Ø12"	725	1235	16	
296222	VS300/2L	Ø12"	505	805	15	
296227	R400/2S	100kg	710	1280	15	



ⓓ Nippelspannfutter / Gewindelehre				
Ⓞ Nipple attachment / Thread gauge				
KW#				
2942**	Nipple attachment 1/2 ~ 4" BSPT / NPT		Pg20	
260***	Thread gauge 1/2 ~ 6" BSPT			



CE230V
R/L



NR50AV

- | | |
|-----------------------------------------------------------------------------------------------------------------------------------------------------------------------------------------------------------------------------------------------------------------------------------------------------------------------------------------------------------|-------------------------------------------------------------------------------------------------------------------------------------------------------------------------------------------------------------------------------------------------------------------------------------------------------------------------------------------------------|
| <p>(D)</p> <ul style="list-style-type: none"> - Kompakt und leicht, 48kg - Kraftvoll, hohe Produktivität - Einfache Bedienung - Einstellbare Gewindetiefe / Länge - Auto. Stop Kohlebürste - Recht / Links Drehung - Schneidköpfe & Schneidbacken austauschbar mit Ridge | <p>(GB)</p> <ul style="list-style-type: none"> - Compact light weight 48kg - Powerful, high productivity - Portable user friendly - Adjustable thread depth/length - Auto. stop carbon brush - Right / Left rotation - Dies & diehead are interchangeable with Ridge |
|-----------------------------------------------------------------------------------------------------------------------------------------------------------------------------------------------------------------------------------------------------------------------------------------------------------------------------------------------------------|-------------------------------------------------------------------------------------------------------------------------------------------------------------------------------------------------------------------------------------------------------------------------------------------------------------------------------------------------------|

(D) NR50AV Gewindeschneidmaschine					
(GB) NR50AV threading machine					
KW#	Type	Max. Cap. Ø			
230354	NR50AV	BSPT/NPT 2" MM52, WW1.1/4" UNC2"	600W 39rpm	48.0	

Dimension : 700(L) x 440(W) x 408 (H) mm

(D) Standard type mit:

(GB) Standard accessory:

- NVR-Auto diehead 1/2-2" (nr.293102),
- Ridge type Alloy dies 1/4x3/8" BSPT (nr.292851),
- Ridge type Alloy dies 1x2"BSPT (nr.292853),
- Reamer, cutter, foot switch, Legs.

(D) Gewindeschneidköpfe				
(GB) Diehead for NR50AV				
KW#	Type	Cap. Ø mm		
293106	NVR auto	1/2 - 2"		Pg12
----- other optional dieheads -----				
293105	VR auto	1/2 - 2"		

(D) Schneidbacken				
(GB) R-type Dies				
KW#	Type	Cap. Ø		
292851	161353	Alloy 1/2 - 3/4" BSPT		Pg13
292853	161354	Alloy 1 - 2" BSPT		
----- other optional dies -----				
2917**		Alloy 1/2 ~ 2" BSPT / NPT		Pg13
2917**		HSS 1/2 ~ 2" BSPT / NPT		
2917**		ARK 1/2 ~ 2" BSPT		

Tapered pipe



VR auto



NVR auto

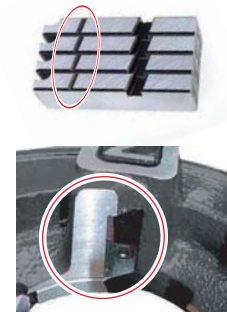

R-type dies

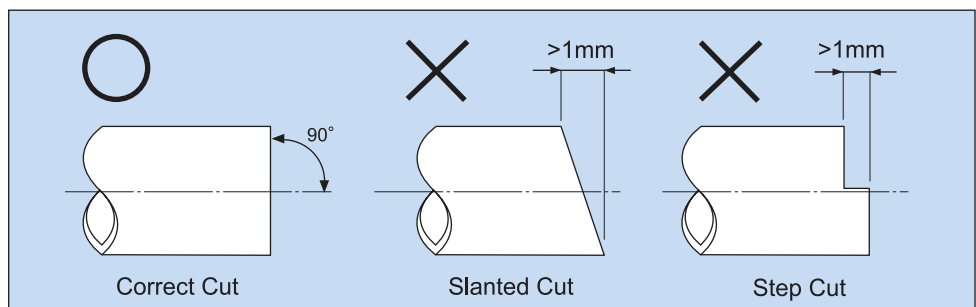

Fig. 1 Acceptable and unacceptable pipe ends

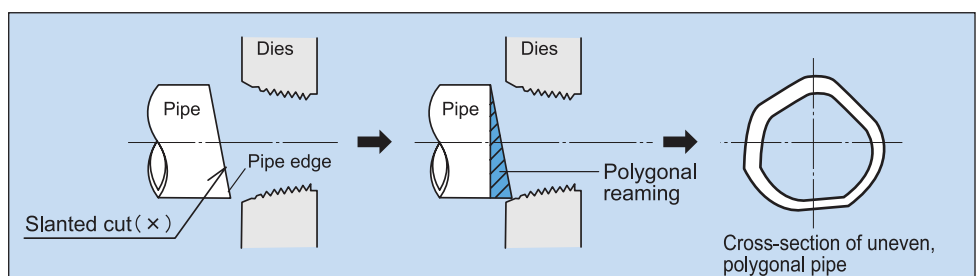

Fig. 3 Principle of polygonal threads



Roll grooving



Ⓓ Rollnutgerät		Ⓔ	
Ⓔ Rollgroove attachment			
KW#	Type		
230913	RGRO	Portable Manual rollgroover 1-6"	Pg16,17
230931	RGRH	Portable Hydr. rollgroover 1-16"	



Ⓓ Rohrschneidräder		Ⓔ	
Ⓔ Machine cutter wheel			
KW#	Type		
295603	135076	Machine cutter wheel	Pg14
285605	135077	HSS machine cutter wheel	



Ⓓ Transportuntergestell		Ⓔ	
Ⓔ Machine cart			
KW#	Type		
296112	170245	Threader cart without adaptor	Pg18
276115	170266	Adaptor for NR50AV	



Ⓓ Rohrständer		Ⓔ				
Ⓔ Pipe support						
KW#	Type	Cap.	H.min	H.max	Ⓔ	
296218	K100	Ø1-4"	850	1100	7.0	Pg19
296223	VS300/2S	Ø12"	725	1235	16	
296222	VS300/2L	Ø12"	505	805	15	
296227	R400/2S	100kg	710	1280	15	



Ⓓ Nippelspannfutter / Gewindelehre		Ⓔ	
Ⓔ Nipple attachment / Thread gauge			
KW#	Type		
2942**	Nipple attachment 1/2 ~ 4" BSPT / NPT		Pg20
260***	Thread gauge 1/2 ~ 6" BSPT		

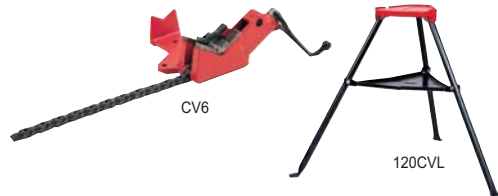

Ⓓ Kettenschraubstöcke		Ⓔ	
Ⓔ Chain vice			
KW#	Type	Cap. Ø	
291230	CV3	1/8 ~ 3"	
291231	CV6	1/8 ~ 6"	
291221	120CVL	stand for CV3, CV6	



Ⓓ Kettenschraubstöcke		Ⓔ	
Ⓔ Chain vice with stand			
KW#	Type	Cap. Ø	
291241	CVX6	1/8 ~ 6"	





CE230V



Ölpumpe



Sicherheit



NP80AV

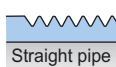
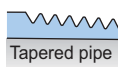

Manual



NVP auto



Super auto



27mm dies



38mm dies

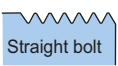

Bolt diehead

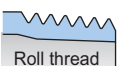

SRH20A

(D)

- Kompakt und leicht, 67kg
- Kraftvoll, hohe Produktivität
- Einfache Bedienung
- Einstellbare Gewindetiefe / Länge
- Auto. Stop Kohlebürste
- Recht / Links Drehung

(GB)

- Compact light weight 67kg
- Powerful, high productivity
- Portable user friendly
- Adjustable thread depth/length
- Auto. stop carbon brush
- Right / Left rotation

(D) NP80AV Gewindeschneidmaschine

(GB) NP80AV REX threading machine

KW#	Type	Max. Cap. Ø		
230307	NP80AV	BSPT/NPT 3" MM52, WW1.1/4" UNC2"	600W 39rpm	67.0

Dimension : 760(L) x 500(W) x 465 (H) mm

(D) Standard typ mit

(GB) Standard accessory:

- NVP-Auto diehead 1/2-2" (nr.293106),
- Manual diehead 2.1/2-3" (nr.
- Alloy dies 1/2x3/4"BSPT (nr.291703),
- Alloy dies 1x2"BSPT (nr.291707),
- Reamer, cutter, foot switch, Legs.

(D) Gewindeschneidköpfe

(GB) Diehead for NP80AV

KW#	Type	Cap. Ø mm	
293106	NVP auto	1/2 - 2"	Pg12
292911	Manual	2.1/2 - 3"	
----- other optional dieheads -----			
292901	Manual	1/4 - 3/8"	
292909	Manual	1/2 - 2"	Pg12
293105	VP auto	1/2 - 2"	
293301	Super auto	1/2 - 3/4"	
293303	Super auto	1 - 2"	
293305	Super auto	2.1/2 - 3"	

(D) Schneidbacken

(GB) Dies

KW#	Type	Cap. Ø	
291703	161907	27mm Alloy 1/2 - 3/4" BSPT	Pg13
291707	16K030	27mm Alloy 1 - 2" BSPT	Pg13
291704	161950	27mm Alloy 2.1/2 - 3" BSPT	Pg13
----- other optional dies -----			
2917**		Alloy 1/4 ~ 2" BSPT / NPT	Pg13
2917**		HSS 1/4 ~ 2" BSPT / NPT	Pg13
2918**		ARK 1/2 ~ 2" BSPT / NPT	Pg13
292***		BoltM8-M52, UNC5/16-2"	Pg14

(D) Bolzengewindeschneidköpfe

(GB) Bolt diehead for NP50AV

KW#	Cap. Ø mm	
2937**	MM, MF, BSW, UNC	Pg12

(D) Roll-köpfe

(GB) Roll diehead

KW#	Cap. Ø	
2938**	3/8 ~ 2"	Pg15

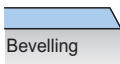
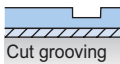

(D) Nutschneidkopt (GB) GB cut grooving / Beveling diehead				
KW#	Type	Cap. Ø	Machine	
293750	GD2	3/4 - 2"	NP50 NP80 N100A	Pg15
293752	GD3	2.1/2 - 3"	NP80 N100A	
----- Schneidbacken -----				
		3/4 ~ 3"	Nutschneidbacken	Pg15
		3/4 ~ 3"	Anfassschneidbacken	



(D) Rollnutgerät (GB) Rollgroove attachment				
KW#	Type			
230913	RGRO	Portable Manual rollgroover 1-6"		Pg16,17
230931	RGRH	Portable Hydr. rollgroover 1-16"		



(D) Rohrschneidräder (GB) Machine cutter wheel				
KW#	Type			
295603	135076	Machine cutter wheel		Pg14
285605	135077	HSS machine cutter wheel		



(D) Transportuntergestell (GB) Machine cart				
KW#	Type			
296112	170245	Threader cart without adaptor		Pg18
276116	1702**	Adaptor for NP80AV		



(D) Rohrständer (GB) Pipe support							
KW#	Type	Cap.	H.min	H.max			
296218	K100	Ø1-4"	850	1100	7.0	Pg19	
296223	VS300/2S	Ø12"	725	1235	16		
296222	VS300/2L	Ø12"	505	805	15		
296227	R400/2S	100kg	710	1280	15		



(D) Nippelspannfutter / Gewindelehre (GB) Nipple attachment / Thread gauge				
KW#				
2942**	Nipple attachment 1/2 ~ 4" BSPT / NPT			Pg20
260***	Thread gauge 1/2 ~ 6" BSPT			



CE 230V



Kondensator-Motor
condensator motor

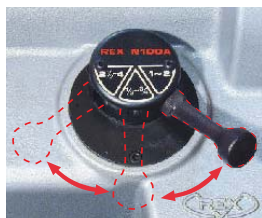

13rpm / 24rpm / 43rpm

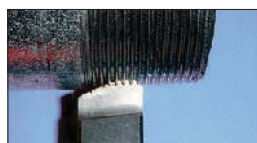

Profiling system



N100A

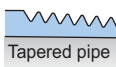

Tapered pipe

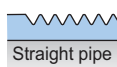

Straight pipe



Manual



NVP auto



Super auto



Profiling



27mm dies



38mm dies



20mm dies

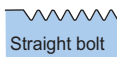

Straight bolt



Bolt diehead

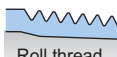

Roll thread



SRH20A

(D)

- Kompakt und leicht, 123kg
- Kraftvoll, hohe Produktivität
- ruhige Kondensator-Motor
- Einstellbare Gewindetiefe / Länge
- Drehzahl 13rpm / 24rpm / 43rpm
- Einzelne Profiling system

(GB)

- Compact light weight 123kg
- Powerful, high productivity
- Quiet condensor motor
- Adjustable thread depth/length
- 3 speed 13rpm / 24rpm / 43rpm
- Unique profiling adjust system

(D) N100A Gewindeschneidmaschine

(GB) N100A REX threading machine

KW#	Type	Max. Cap. Ø	MOTOR	Lock
230311	N100A	BSPT/NPT 4" MM52, WW1.1/4" UNC2"	750W 43, 24, 13rpm	123

Dimension : 873(L) x 635(W) x 558 (H) mm

(D) Standard typ

(GB) Standard accessory:

- NVP-Auto diehead 1/2-2" (nr.293106),
- Profiling diehead 2.1/2-4" (nr.293505)
- Alloy dies 1/4x3/8"BSPT (nr.291703),
- Alloy dies 1x2"BSPT (nr.291707),
- 20mm dies Alloy 2.1/2-4" (nr.292105)
- Reamer, cutter, foot switch, Legs.

(D) Gewindeschneidköpfe

(GB) Diehead for N100A

KW#	Type	Cap. Ø mm	Book
293106	NVP auto	1/2 - 2"	Pg12
293505	Profiling	2.1/2 - 4"	
----- other optional dieheads -----			
292901	Manual	1/4 - 3/8"	Pg12
293105	Manual	1/2 - 2"	
293105	Manual	2.1/2 - 3"	
293105	NV auto	1/2 - 2"	
293301	Super auto	1/2 - 3/4"	
293303	Super auto	1 - 2"	
293305	Super auto	2.1/2 - 3"	

(D) Schneidbacken

(GB) Dies

KW#	Type	Cap. Ø	Book
291703	161907	27mm Alloy 1/2 - 3/4" BSPT	Pg13
291707	16K030	27mm Alloy 1 - 2" BSPT	Pg13
292105	162460	20mm Alloy 2.1/2 - 4" BSPT	Pg13
----- other optional dies -----			
2917**		Alloy 1/4 ~ 2" BSPT / NPT	Pg13
2917**		HSS 1/4 ~ 2" BSPT / NPT	Pg13
2918**		ARK 1/2 ~ 2" BSPT / NPT	Pg13
292***		BoltM8~M52, UNC5/16~2"	Pg14

(D) Bolzengewindeschneidköpfe

(GB) Bolt diehead for N100A

KW#	Cap. Ø mm	Book
2937**	MM, MF, BSW, UNC	Pg12

(D) Roll-köpfe

(GB) Roll diehead

KW#	Cap. Ø	Book
2938**	3/8 ~ 2"	Pg15

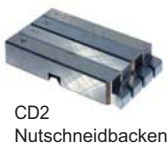
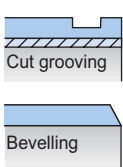

ⓓ Nutenschneidkopt				
Ⓤ GB cut grooving / Beveling diehead				
KW#	Type	Cap. Ø	Machine	
293750	GD2	3/4 - 2"	NP50A NP80A N100A	Pg15
293752	GD3	2.1/2 - 3"	NP80A N100A	
293753	PGD4	2.1/2 - 4"	N100A	
----- Schneidbacken -----				
		3/4 ~ 3"	Nutschneidbacken	Pg15
		3/4 ~ 3"	Anfassschneidbacken	

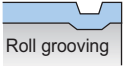

ⓓ Rollnutgerät			
Ⓤ GB Rollgroove attachment			
KW#	Type		
230913	RGRO	Portable Manual rollgroover 1-6"	Pg16,17
230931	RGRH	Portable Hydr. rollgroover 1-16"	



ⓓ Rohrschneidräder			
Ⓤ GB Machine cutter wheel			
KW#	Type		
295603	135076	Machine cutter wheel	Pg14
285605	135077	HSS machine cutter wheel	



Blade-type cutter on N100A



ⓓ Rohrschneidräder			
Ⓤ GB Blade type cutter			
KW#	Type		
295***	13MP10	Machine cutter wheel	



ⓓ Rohrständer						
Ⓤ GB Pipe support						
KW#	Type	Cap.	H.min	H.max	Weight	
296218	K100	Ø1-4"	850	1100	7.0	Pg19
296223	VS300/2S	Ø12"	725	1235	16	
296222	VS300/2L	Ø12"	505	805	15	
296227	R400/2S	100kg	710	1280	15	



ⓓ Nippelspannfutter / Gewindelehre			
Ⓤ GB Nipple attachment / Thread gauge			
KW#			
2942**		Nipple attachment 1/2 ~ 4" BSPT / NPT	Pg20
260***		Thread gauge 1/2 ~ 6" BSPT	

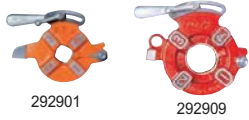

292901 292909



VP auto



NVP auto



Super auto



Profiling



VR-type



NVR-type



Bolt diehead

Ⓚ Gewindeschneidköpfe ⓁⓇ Threading diehead						
Diehead type type	KW#	Ø	Schneidbacken		Machine series	
			Type	Width		
Pipe thread, Manual (Right)	292901	1/4 - 3/8"	BSPT, BSPP, NPT	23 mm	40A, 50A, 80A, 100A	
	292905	1/2 - 1.1/2"	BSPT	27 mm	40A, 50A, 80A, 100A	
	292909	1/2 - 2"	BSPT, BSPP, NPT	27 mm	50A, 80A, 100A	
	292911	2.1/2 - 3"	BSPT, BSPP, NPT	27 mm	80A, 100A	
Pipe thread, Auto open VP-type (Right)	293103	1/2 - 1.1/2"	BSPT	27 mm	40A, 50A, 80A, 100A	
	293105	1/2 - 2"	BSPT, BSPP, NPT	27 mm	50A, 80A, 100A	
Pipe thread, Auto open NVP-type (Right)	293106	1/2 - 2"	BSPT, BSPP, NPT	27 mm	50A, 80A, 100A	
Pipe thread, Auto open, Super fine adjustment Super auto type (Right)	293301	1/2 - 3/4"	BSPT, BSPP, NPT	27 mm	40A, 50A, 80A, 100A	
	293303	1 - 2"	BSPT, BSPP, NPT	38 mm	50A, 80A, 100A	
	293305	2.1/2 - 3"	BSPT, BSPP, NPT	38 mm	80A, 100A	
Pipe thread, Auto open Profiling type (Right)	293501	1/2 - 3/4"	BSPT, NPT	20 mm	100ADX	
	293502	1 - 2"	BSPT, NPT	20 mm	100ADX	
	293503	2.1/2 - 3"	BSPT, NPT	20 mm	100ADX	
	293505	2.1/2 - 4"	BSPT, NPT	20 mm	100A, 150A	
	293507	5 - 6"	BSPT, NPT	20 mm	150A	
Pipe thread, Auto open VR-type Ridge compatible (Right)	293101	1/2 - 2"	BSPT, NPT	27 mm	R50, NR50	
Pipe thread, Auto open NVR-type Ridge compatible (Right)	293102	1/2 - 2"	BSPT, NPT	27 mm	R50, NR50	
Bolt thread, Manual (Right)	293701	M8 - 52	Metric	27 mm	50A, 80A, 100A	
	293702	MF20 - 32	Metric fine (p1.5)	27 mm	50A, 80A, 100A	
	293703	5/16 - 7/8	BSW	27 mm	50A, 80A, 100A	
	293704	1 - 1.1/4"	BSW	27 mm	50A, 80A, 100A	
	293705	5/16 - 2"	UNC	27 mm	50A, 80A, 100A	

REX

Ⓚ Gewindeschneidmaschine ⓁⓇ Threading machine			OLD ← → NEW	2011
1" / 25A series				Not for EU
1.1/2" / 40A series				Not for EU
2" / 50A series				NP50A
3" / 80A series				NP80A
4" / 100A series				N100A
6" / 150A series				Not for EU
R-type 2" / R50A series				NR50A



hand grinder
1925



Oster type threader
1946



2" machine
1959



6" machine
1959



Easy change dies



Notches in dies



Spring ball



R50AV

NR50AV



VR-type

NVR-type

Ⓧ REX Schneidbacken Ⓞ REX dies						
Thread type	Ø	Width	KW#			Schneidkopf (KW#)
			Alloy	HSS	ARK	
Pipe thread, Tapered, (Right) [R] BSPT ISO7-1	1/4 - 3/8"	23mm	291701	291721	-	292901
	1/2 - 3/4"	27mm	291703	291723	291803	292909, 293105, 293106, 293301
	1 - 2"	27mm	291707	291727	291807	292909, 293105, 293106
		38mm	291903	292003	-	293303
	2.1/2 - 3"	27mm	291704	291729	-	292911
		38mm	291905	292005	-	293305
	1/2 - 3/4"	20mm	292101	292109	-	293501
		20mm	292103	292111	-	293502
	2.1/2 - 4"	20mm	292105	292113	-	293505
		20mm	292107	292115	-	293507
Pipe thread, Parallel, (Right) [G] BSPP (PF) ISO228-1, BS2779	1/4 - 3/8"	23mm	291731	-	-	292901
	1/2 - 3/4"	27mm	291733	-	-	292909
	1 - 2"	27mm	291735	-	-	292909
	2.1/2 - 3"	27mm	291737	-	-	292911
Pipe thread, Tapered, (Right) [NPT] ANSI/ASME B1.20.1	1/4 - 3/8"	23mm	291739	291747	-	292901
	1/2 - 3/4"	27mm	291741	291749	-	292909, 293105, 293106, 293301
	1 - 2"	27mm	291743	291751	-	292909, 293105, 293106
		38mm	291915	292009	-	293303
	2.1/2 - 3"	27mm	291745	291753	-	292911
	1/2 - 3/4"	20mm	292117	292125	-	293501
		20mm	292119	292127	-	293502
	2.1/2 - 4"	20mm	292121	292129	-	293505
		20mm	292123	292131	-	293507

- Alloy dies (standard) for steel pipe
- HSS dies for stainless (INOX) pipe
- ARK dies for steel pipe, high quality

Ⓧ R - type dies (austauschbar mit Ridge dies) Ⓞ R - type dies (compatible with Ridge dies)						
Thread type	Ø	Width	KW#			Schneidkopf (KW#)
			Alloy	HSS	ARK	
Pipe thread, Tapered, (Right), [R], BSPT ISO7-1	1/2 - 3/4"	27mm	292851	292861	292871	293101, 293102
	1 - 2"	27mm	292853	292863	292873	293101, 293102
Pipe thread, Tapered, (Right), [NPT] ANSI/ASME B1.20.1	1/2 - 3/4"	27mm	29****	29****	-	293101, 293102
	1 - 2"	27mm	29****	29****	-	293101, 293102

- Alloy dies (standard) for steel pipe
- HSS dies for stainless (INOX) pipe
- ARK dies for steel pipe, high quality

Straight bolt



ⓓ Schneidbacken für metrische Bolzengewinde
Ⓞ Bolt dies

Thread type	Ø	Pitch	KW#			Schneidkopf (KW#)
			Alloy	HSS	ARK	
Metrische [M] ISO261 / 68-1	M8	1.25	292301	-	-	293701
	M10	1.5	292303	-	-	293701
	M12	1.75	292305	-	-	293701
	M14-16	2.0	292307	-	-	293701
	M18-22	2.5	292309	-	-	293701
	M24-27	3.0	292311	-	-	293701
	M30-33	3.5	292313	-	-	293701
	M36-39	4.0	292315	-	-	293701
	M42-45	4.5	292317	-	-	293701
	M48-52	5.0	292319	-	-	293701
	MF18-22	1.5	292401	-	-	293702
MF24-27	1.5	291403	-	-	293702	
MF30-32	1.5	291405	-	-	293702	
Unified National Coarse thread, [UNC] ANSI B1.1	UNC5/16"	18pi	292701	-	-	293705
	UNC3/8"	16pi	292703	-	-	293705
	UNC7/16"	14pi	292705	-	-	293705
	UNC1/2"	13pi	292707	-	-	293705
	UNC5/8"	11pi	292709	-	-	293705
	UNC3/4"	10pi	292711	-	-	293705
	UNC7/8"	9pi	292713	-	-	293705
	UNC1"	8pi	292715	-	-	293705
	UNC1.1/4"	7pi	292717	-	-	293705
	UNC1.1/2"	6pi	292719	-	-	293705
UNC2"	4.5pi	292721	-	-	293705	
British Standard Whitworth thread, [BSW]	BSW5/16"	18pi	292501	-	-	293703
	BSW3/8"	16pi	292503	-	-	293703
	BSW7/16"	14pi	292505	-	-	293703
	BSW1/2"	12pi	292507	-	-	293703
	BSW5/8"	11pi	292509	-	-	293703
	BSW3/4"	10pi	292511	-	-	293703
	BSW7/8"	9pi	292513	-	-	293703
	BSW1"	8pi	292515	-	-	293704
BSW1.1/4"	7pi	292517	-	-	293704	



ⓓ Rohrschneidräder
Ⓞ Machine cutter wheel

KW#	Type	
295603	135076	Machine cutter wheel
285605	135077	HSS machine cutter wheel

- Alloy (standard) for steel pipe
- HSS for stainless (INOX) pipe



ⓓ Magnet Späneheber, Bürsten
Ⓞ Cleaning magnet, Brush

KW#	Type	
295	17027A	Magneter 60 x 98 x h198
285	17027B	Magnet 64 x 76 x h18
696250	HC-1	Magnet bar L:400mm
285	472000	Scrap brush



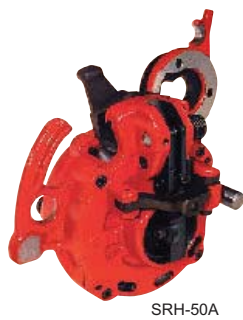

SRH-50A



250600



250632

ⓓ Roll-köpfe
ⓖⓑ Roll thread head

KW#	Type	∅	Machine
293861	SRH-10A	3/8" BSPT	50A, 80A, 100A
293863	SRH-15A	1/2" BSPT	50A, 80A, 100A
293865	SRH-20A	3/4" BSPT	50A, 80A, 100A
293867	SRH-25A	1" BSPT	50A, 80A, 100A
293869	SRH-32A	1.1/4" BSPT	80A, 100A
293871	SRH-40A	1.1/2" BSPT	80A, 100A
293873	SRH-50A	2" BSPT	80A, 100A

ⓓ Roll Kopf brauchen besondere Messerführung auf der Maschine.
ⓖⓑ Roll head requier special cutter guide on the machine.

ⓓ Roll-köpfe Zubehör
ⓖⓑ Roll thread head accessories

KW#	Type	
292	250700	Cutter guide for N50A, P50, NP50
292	250701	Cutter guide for N80A
292	250702	Cutter guide for N100A
292	250600	Roll thread sealant ZT
292	250615	Lining blade 1/2" for SRH-15A
292	250620	Lining blade 3/4" for SRH-20A
292	250625	Lining blade 1" for SRH-25A
292	250632	Lining blade 1.1/4" for SRH-32A
292	250640	Lining blade 1.1/2" for SRH-40A
292	250650	Lining blade 2" for SRH-50A

Roll threading vs. Cut threading

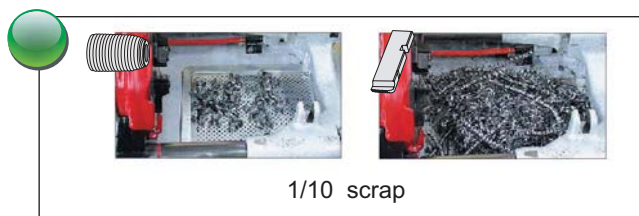
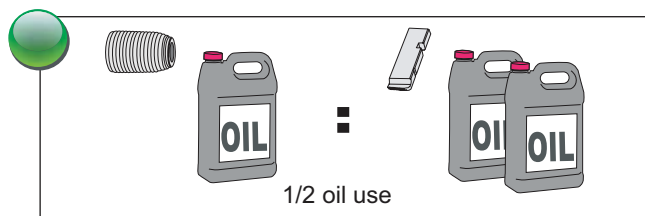
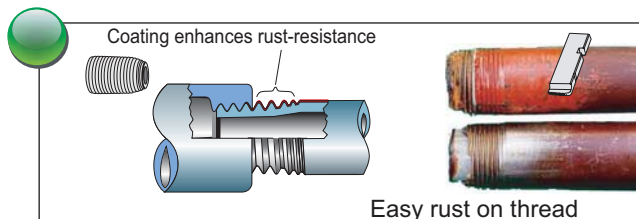
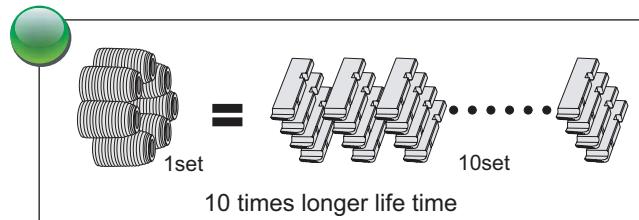
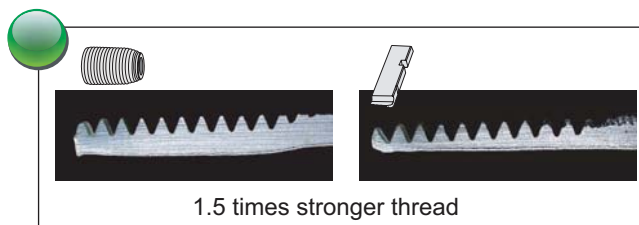
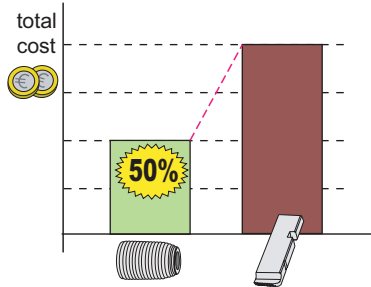
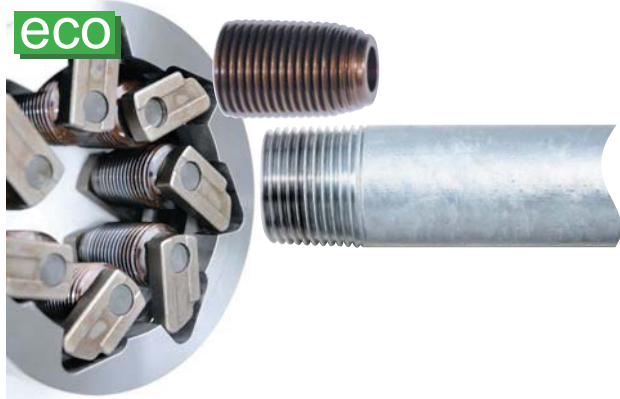

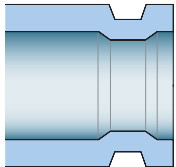

- (D)** - Kompakt, leicht
- (D)** - Minimaler kraftaufwand
- (D)** - Einfaches monieren auf jede Gewindeschneidmaschine
- (GB)** - Compact Leight weight - easy
- (GB)** - Minimal grooving force
- (GB)** - Simple attaching and replacing on every threading machine

(D) Manuelle Rollnutgeräte
(GB) Portable manual groover

KW#	Type	Cap. Ø mm		
230914	RGRO	1-6"	sched. 10	12.0
		1-3"	sched. 40	

Dimension : L200xW220xH260mm

- (D)** Standard typ mit Nutensatz 2-6", ohne Montagesockel bitte bestellen Sie den Montagesockel für entsprechend Gewindeschneidmaschine
- (GB)** Standard type with Roller 2-6", without mountbase/adaptor

(D) Nutensatz : RGRO
(GB) Roller set for RGRO

KW#	Type	Cap. Ø mm		
276121	341551	1"	sched. 10, 40	
276122	341552	1¼-1½"	sched. 10, 40	
276124	341558	2-6" & 2-3"	sched. 10 & 40	

(D) Montagesockel
(GB) Mount base (adaptor) for RGRO

KW#	Type	Machine	
295551	M-R1	ReX: N50-P50-R50-NP50-NR50	
295513	M-R2	ReX: N80-S80	
295514	M-R3	ReX: N100	
295515	M-E1	Ridgid 300	
295517	M-E2	Ridgid 300 compact 1233	
295519	M-E3	Ridgid 1224	
295516	M-E0	Ridgid 535	
295521	M-E4	ReMS: Tornado, Magnum	
295521	M-E4	Roller: Robot 2-3-4	

- (D)** Bleispiele "Prefabrication"
- (GB)** Rollgrooved pipe prefabrication production line from our group company, MPS.



- (D)** Produktions Rollnutmaschinen
- (GB)** Production roll groover

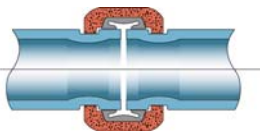



Easy mount

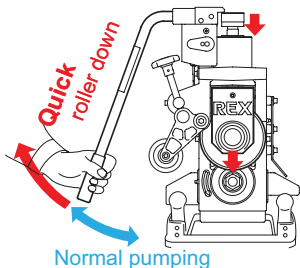

Light weight



Einschließlich Führungsrolle
Include guide roller



RGRH



M-HR1



GN3

RT1

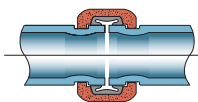

- (D)**
 - Große Kapazität 16"
 - Kompakt und leicht
 - Einfache Bedienung durch Führungsrolle
- (GB)**
 - Large capacity upto 16"
 - Compact & light weight
 - Easy operation with guide roller
 - Easy to mount on machine

(D) Hydraulische Rollnutgeräte		(GB) Portable hydraulic groover		
KW#	Type	Cap. Ø mm	kg	
230931	RGRH	1-16" sched. 10 Fe	35.8	
		1-12" sched. 40 Fe		
		2-3" sched. 5-10 Inox		
		4-6" sched. 5-10 Inox		

Dimension : 272(w) x 478(d) x 385 (h) mm

(D) Standard typ mit Nutensatz 2-6", ohne Motagesockel bitte bestellen Sie den Montagesockel für entsprechend Gewindeschneidmaschine

(GB) Standard type with Roller 2-6", without mountbase/adaptor

(D) Nutensatz : RGRH		(GB) Roller set for RGRH		
KW#	Type	Cap. Ø mm		
276106	341112+4	1-1½" sched. 40 with shaft		
276107	341133	2-6" sched. 40		
276109	341111	8-12" sched. 10		
276110	341137	10-12" sched. 40		
276161	341138	14-16" sched. 10		
276171	341118	1-1½" sched. 5-10 Inox		
276173	341119	2-3" sched. 5-10 Inox		
276175	341120	4-6" sched. 5-10 Inox		

(D) Montagesatz		(GB) Mount kit (adaptor) for RGRH		
KW#	Type	Machine		
295541	M-HR1	Rex: N50-P50-R50-NP50-NR50		
295543	M-HR2	Rex: N80-S80		
295544	M-HR3	Rex: N100		
295545	M-HE1	Ridgid 300		
295	M-HE2	Ridgid 300 compact		

(D) Tiefeneinstellehre		(GB) Depth gauge		
KW#	Type	Cap. Ø mm		
560021	GN3	Go/Non-Go gauge		
560011	341125	1-6" depth gauge		
560013	341124	8-12" depth gauge		
560015	341139	14-16" depth gauge		
560001	RT1	1-16" OD tape		

CAUTION

- The specified size for each part of the pipe may differ slightly, depending on the joint.
- In such a case, make sure you check the machining size according to the specified size table for the joint used.

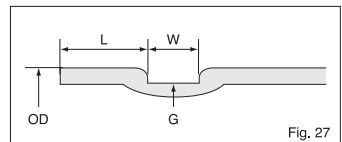
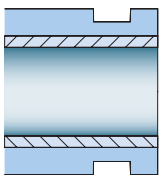
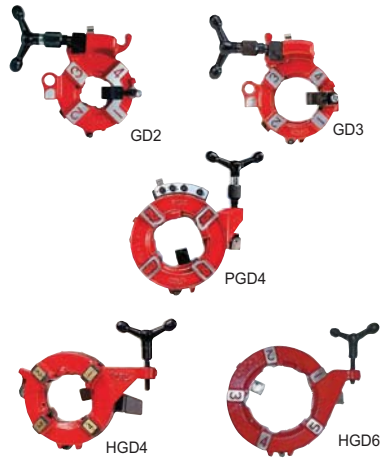
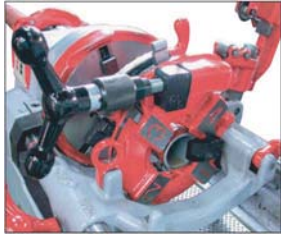
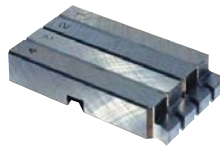

Table 6 Roll Groove Standard Machining Size

Nominal	Pipe outer diameter (O.D)		Seal surface width (L)		Groove width (W)		Groove diameter (G)	
	A	B						
25	1	34.0	16.0	+0.4 -0.9	7.1	±0.8	30.4	0 -0.1
32	1¼	42.7	16.0	+0.4 -0.9	7.1	±0.8	39.1	0 -0.1
40	1½	48.6	16.0	+0.4 -0.9	7.1	±0.8	45.0	0 -0.1
50	2	60.5	16.0	+0.4 -0.9	8.7	±0.8	56.9	0 -0.1
65	2½	76.3	16.0	+0.4 -0.9	8.7	±0.8	72.2	0 -0.1
80	3	89.1	16.0	+0.4 -0.9	8.7	±0.8	84.9	0 -0.1
100	4	114.3	16.0	+0.4 -0.9	8.7	±0.8	110.1	0 -0.1
125	5	139.8	16.0	+0.4 -0.9	8.7	±0.8	135.5	0 -0.1
150	6	165.2	16.0	+0.4 -0.9	8.7	±0.8	160.8	0 -0.1
200	8	216.3	19.0	±0.8	11.9	±0.8	211.6	0 -0.1
250	10	267.4	19.0	±0.8	11.9	±0.8	262.6	0 -0.1
300	12	318.5	19.0	±0.8	11.9	±0.8	312.9	0 -0.1



Nutschneid
Cut grooving



CD2

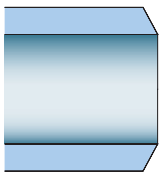

Anfasen
Bevelling



16H730



170245

(D) Nuten- / Anfassschneidkopt (GB) GB cut grooving / Bevelling diehead				
KW#	Type	Cap. Ø	Machine	
293750	GD2	3/4 - 2"	NP50A S80A N100A	
293752	GD3	2.1/2 - 3"	S80A N100A	
293753	PGD4	2.1/2 - 4"	N100A	
293755	HGD4	2.1/2 - 4"	150A	
293757	HGD6	5 - 6"	150A	

(D) Nutschneidbacken (GB) Cut grooving dies				
KW#	Type	Cap. Ø	G. Diehead	
293801	CD3/4	3/4"	GD2	
293803	CD2	1 - 2"	GD2	
293805	CD3	2.1/2 - 3"	GD3	
293807	CD3.1/2	2.1/2 - 3.1/2"	PGD4, HGD4	
293809	CD4	4"	PGD4, HGD4	
293811	CD6	5 - 6"	HGD6	

(D) Anfassschneidbacken (GB) Bevelling dies				
KW#	Type	Cap. Ø	G. Diehead	
293822	16H707	3/4" 30°	GD2	
293821	16H807	3/4" 37.5°	GD2	
293820	16H730	1-2" 30°	GD2	
293819	16H830	1-2" 37.5°	GD2	
293818	16H750	2.1/2-3" 30°	GD3	
293817	16H850	2.1/2-3" 37.5°	GD3	
293816	162760	2.1/2-4" 30°	PGD4, HGD4	
293815	162860	2.1/2-4" 37.5°	PGD4, HGD4	
293814	162862	2.1/2-4" 45°	PGD4, HGD4	
293813	162770	5-6" 30°	HGD6	
293812	162870	5-6" 37.5°	HGD6	
293810	162872	5-6" 45°	HGD6	

(D) Transportuntergestell (GB) Machine cart				
KW#	Type			
296112	170245	Threader cart without adaptor		
276113	170255	Adaptor for N50, P50, R50		
276115	170266	Adaptor for NP50, NR50		
276114	170265	Adaptor for N80, S80		



K100



VS300/2S



HS150



HG200



LG150



PSG3A



PSG2A



PSG5A



PSG4A



R400/2S



R500/2S



120CVL

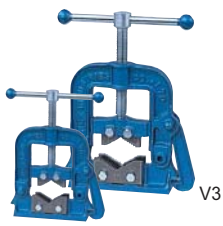

V3

V1

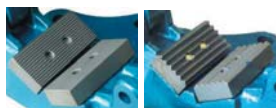

V - type

VL - type

Ⓛ Rohrständer
Ⓜ Pipe support

KW#	Type	Cap. Ø	H.min	H.max	Ⓛ	
296218	K100	1-4"	850	1100	7.0	
296223	VS300/2S	12"	725	1235	16	
296222	VS300/2L	12"	505	805	15	

Ⓛ Rohrständer
Ⓜ Pipe support

KW#	Type	Cap. Ø	H.min	H.max	Ⓛ	
296213	HS150	1-6"	340	475	6.0	
296212	HG200	1-8"	550	1050	11	
296210	LG150	1-6"	630	795	12	
296214	LG300	8-12"	471	668	16	

Ⓛ Rohrständer
Ⓜ Pipe support

KW#	Type	Cap. Ø mm	Ⓛ	
296181	PSG3A	1-4"		
296182	PSG2A	2-12"		
296183	PSG5A	2-6"		
296185	PSG4A	8-24"		

Ⓛ Rollständer
Ⓜ Roll support

KW#	Type	W. mm	Cap. Kg	H. ↓ mm	
296227	R400/2S	400	100	710 - 1280	
296225	R400/2L	400	100	460 - 780	
296221	R500/2S	500	200	685 - 1185	
296230	R500/2L	500	200	455 - 755	

Ⓛ Rohrschraubstöcke
Ⓜ Pipe vice

KW#	Type	Cap. Ø		
291201	V0	1/8 - 2"		
291203	V1	1/8 - 2.1/2"		
291207	V3	1/8 - 4.1/2"		for steel pipe
291205	V2	1/8 - 3.1/2"		
291209	V4	1/8 - 6"		
291211	V0L	1/8 - 2"		
291213	V1L	1/8 - 2.1/2"		
291217	V3L	1/8 - 4.1/2"		for coated pipe
291215	V2L	1/8 - 3.1/2"		
291219	V4L	1/8 - 6"		
291221	120CVL	1/8 - 6"		stand

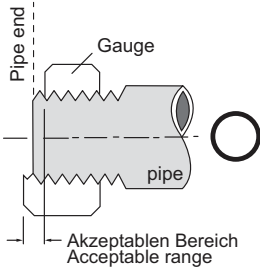
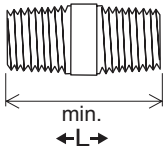
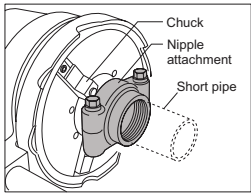

Gewindedurchmesser ist zu klein
Thread diameter is too small.

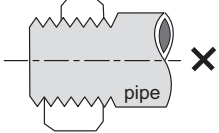

Gewindedurchmesser ist zu groß.
Thread diameter is too large.

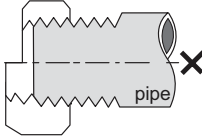

246-R



50W-R



100SW-R

(D) Nippelspannfutter
(GB) Nipple attachment

BSPT		NPT		Ø	min. ←L→	
KW#	Type	KW#	Type			
294201	1701NA	294227	1701N0	1/2"	45	
294203	1701NB	294229	1701N1	3/4"	50	
294205	1701NC	294231	1701N2	1"	55	
294207	1701ND	294233	1701N3	1.1/4"	65	
294209	1701NE	294235	1701N4	1.1/2"	65	
294211	1701NF	294237	1701N5	2"	70	
294213	1701NG	294239	1701N6	2.1/2"	75	
294215	1701NH	294241	1701N7	3"	80	
294219	1701NK	294245	1701N9	4"	100	
292***	-	T-wrench M10x17				

(D) Gewindelehre
(GB) Thread gauge for BSPT

KW#	Type	Ø	
260101	473010	1/2"	
260103	473011	3/4"	
260105	473012	1"	
260107	473013	1.1/4"	
260109	473014	1.1/2"	
260111	473015	2"	
260113	473016	2.1/2"	
260115	473017	3"	
260119	473019	4"	
260121	473020	5"	
260123	473021	6"	
260301	473001	set 1/2, 3/4, 1"	
260303	473002	set 1/2, 3/4, 1, 1.1/4, 1.1/2, 2"	

(D) Gewindeschneidmittel
(GB) Cutting oil

KW#	Type	description	
292***	246-R 4L	Standard	
292***	246-R 18L	-	
292***	246-R 200L	-	
292***	N246 18L	Special export	
292***	N246 200L	-	
292***	50W-R 4L	Water soluble	
292***	50W-R 16L	-	
292	50W-R 200L	-	
292***	N50W 16L	Water soluble, Special export	
292***	N50W 200L	-	
292***	100SW-R 4L	for Stainless steel pipe only	
292***	100SW-R 16L	-	
292***	100SW-R 200L	-	